



MODUS												
	Modello Model Modèle Modelo	Teglie Trays Plaques Bandejas	Dim. teglie Trays dim. Dim. plaques Dim. bandejas	Dimensioni camere Deck dimensions Dimensions Chambres Dimensions cámaras			Dimensioni esterne Outside dimensions Dimensions extérieures Dimensions externas			Potenza Power Puissance Potencia	ECO ECO ECO ECO	Peso Weight Poids Peso
				A	B	H1	C	D	H2			
				cm	cm	cm	cm	cm	cm			
 LFM 2T 6040	LFM-2T-6040	2	40X60	62	85	18/24	93	128	31/37	5.9	3	104
	LFM-2T-6040-V	2	40X60	62	85	18/24	93	128	31/37	8.3	4.5	140
	TOP**	---	---	---	---	---	93	128	7	---	---	54
	STAND	10/14	40X60	---	---	---	93	112	87/55*	---	---	73/35
	CELLA	10/14	40X60	---	---	---	93	125	94/74*	2.3	---	91
	CAPPA	---	---	---	---	---	93	132	26	0.2	---	24
 LFM 2T 4060	LFM-2T-4060	2	40X60	82	70	18/24	113	113	31/37	6.4	3.5	111
	LFM-2T-4060-V	2	40X60	82	70	18/24	113	113	31/37	8.8	4.8	145
	TOP**	---	---	---	---	---	113	113	7	---	---	59
	STAND	10/14	40X60	---	---	---	113	97	87/55*	---	---	80/37
	CELLA	10/14	40X60	---	---	---	113	110	94/74*	2.3	---	106
	CAPPA	---	---	---	---	---	113	117	26	0.2	---	25
 LFM 3T 4060	LFM-3T-4060	3	40X60	124	70	18/24	155	113	31/37	9.6	5	148
	LFM-3T-4060-V	3	40X60	124	70	18/24	155	113	31/37	12	6.5	182
	TOP**	---	---	---	---	---	155	113	7	---	---	80
	STAND	20/28	40X60	---	---	---	155	117	87/55*	---	---	84/43
	CELLA	20/28	40X60	---	---	---	155	130	94/74*	2.3	---	119
	CAPPA	---	---	---	---	---	155	117	26	0.2	---	30

TOP = Isolamento superiore e inferiore moduli forno - Top and base insulation - Isolation supérieure et inférieure des modules de four- Aislamiento superior y inferior de los módulos horno

STAND = Supporto- Stand- Support- Soporte

CELLA = Cella di lievitazione - Proofer- Chambre de fermentation- Cámara de fermentación

CAPPA = Cappa- Hood- Hotte- Campana

* Supporto per forni a 4 o 5 camere

* Stand for ovens with 4 or 5 decks

* Support pour les fours à 4 ou 5 chambres

* Soporte para hornos con 4 o 5 cámaras

** 2 pezzi per forno

** 2 pieces for oven

** 2 pieces for oven

** 2 piezas para horno

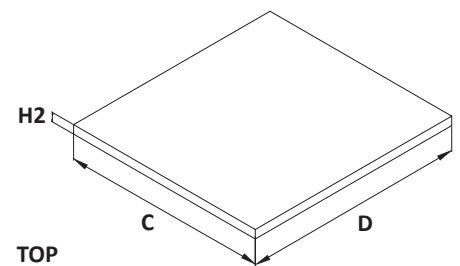
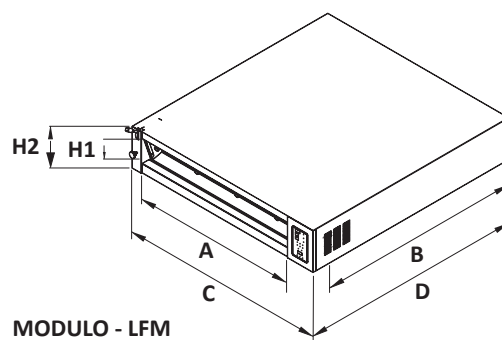
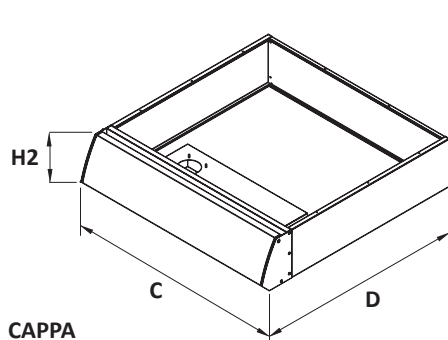

MODUS

	Modello Model Modèle Modelo	Teglie Trays Plaques Bandejas	Dim. teglie Trays dim. Dim. plaques Dim. bandejas	Dimensioni camere Deck dimensions Dimensions Chambres Dimensions cámaras			Dimensioni esterne Outside dimensions Dimensions extérieures Dimensiones externas			Potenza Power Puissance Potencia	ECO ECO ECO ECO	Peso Weight Poids Peso
				A	B	H1	C	D	H2			
				cm	cm	cm	cm	cm	cm			
LFM 4T 4060	LFM-4T-4060	4	40X60	82	125	18/24	113	168	31/37	8.7	4.8	160
	LFM-4T-4060-V	4	40X60	82	125	18/24	113	168	31/37	11.1	6	193
	TOP**	---	---	---	---	---	113	168	7	---	---	87
	STAND	20/28	40X60	---	---	---	113	152	87/55*	---	---	105/44
	CELLA	20/28	40X60	---	---	---	113	165	94/74*	2.3	---	133
	CAPPA	---	---	---	---	---	113	172	26	0.2	---	28
LFM 4T 6040	LFM-4T-6040	4	40X60	124	85	18/24	155	128	31/37	11.5	6	183
	LFM-4T-6040-V	4	40X60	124	85	18/24	155	128	31/37	13.9	7.5	199
	TOP**	---	---	---	---	---	155	128	7	---	---	89
	STAND	20/28	40X60	---	---	---	155	112	87/55*	---	---	92/45
	CELLA	20/28	40X60	---	---	---	155	125	94/74*	2.3	---	127
	CAPPA	---	---	---	---	---	155	132	26	0.2	---	31
LFM 6T 6040	LFM-6T-6040	6	40X60	124	125	18/24	155	168	31/37	13.1	7	216
	LFM-6T-6040-V	6	40X60	124	125	18/24	155	168	31/37	15.5	8.5	250
	TOP**	---	---	---	---	---	155	168	7	---	---	117
	STAND	30/42	40X60	---	---	---	155	152	87/55*	---	---	112/51
	CELLA	30/42	40X60	---	---	---	155	165	94/74*	2.3	---	147
	CAPPA	---	---	---	---	---	155	172	26	0.2	---	33



TOP = Isolamento superiore e inferiore moduli forno - Top and base insulation - Isolation supérieure et inférieure des modules de four- Aislamiento superior y inferior de los módulos horno

STAND = Supporto- Stand- Support- Soporte

CELLA = Cella di lievitazione - Proofer- Chambre de fermentation- Cámara de fermentación

CAPPA = Cappa- Hood- Hotte- Campana

* Supporto per forni a 4 o 5 camere

* Stand for ovens with 4 or 5 decks

* Support pour les fours à 4 ou 5 chambres

* Soporte para hornos con 4 o 5 cámaras



** 2 pezzi per forno

** 2 pieces for oven

** 2 pieces for oven

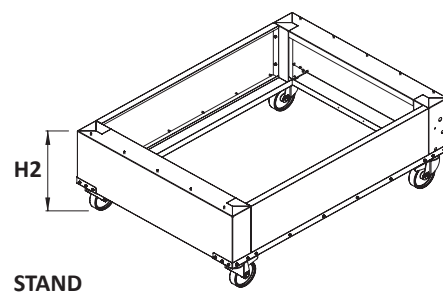
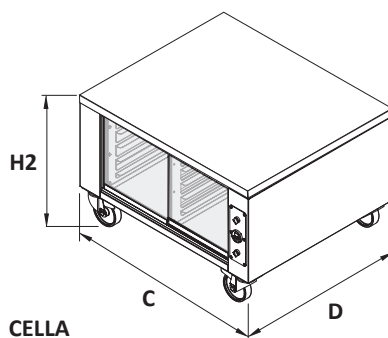
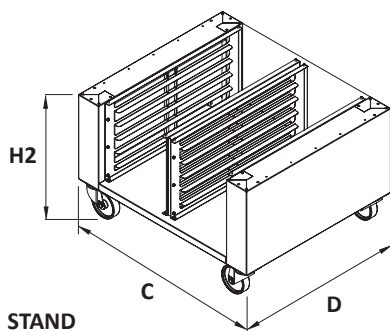
** 2 piezas para horno



MODUS												
	Modello Model Modèle Modelo	Teglie Trays Plaques Bandejas	Dim. teglie Trays dim. Dim. plaques Dim. bandejas	Dimensioni camere Deck dimensions Dimensions Chambres Dimensiones cámaras			Dimensioni esterne Outside dimensions Dimensions extérieures Dimensiones externas			Potenza Power Puissance Potencia	ECO ECO ECO ECO	Peso Weight Poids Peso
				A	B	H1	C	D	H2			
				cm	cm	cm	cm	cm	cm			
 ▲ LFM 2T 6646 - 7646	LFM-2T-6646-7646	2	46X76 - 46X66	82	105	18/24	113	148	31/37	8.7	4.8	151
	LFM-2T-6646-7646-V	2	46X76 - 46X66	82	105	18/24	113	148	31/37	11.1	6	178
	TOP**	---	---	---	---	---	113	148	7	---	---	71
	STAND	10/14	46X76 - 46X66	---	---	---	113	132	87/55*	---	---	96/42
	CELLA	10/14	46X76 - 46X66	---	---	---	113	145	94/74	2.3	---	103
	CAPPA	---	---	---	---	---	113	152	26	0.2	---	27
 ▲ LFM 2T 4666 - 4676	LFM-2T-4666-4676	2	46X76 - 46X66	102	85	18/24	133	128	31/37	9.6	5	144
	LFM-2T-4666-4676-V	2	46X76 - 46X66	102	85	18/24	133	128	31/37	12	6.5	178
	TOP**	---	---	---	---	---	133	128	7	---	---	77
	STAND	10/14	46X76 - 46X66	---	---	---	133	112	87/55*	---	---	90/42
	CELLA	10/14	46X76 - 46X66	---	---	---	133	125	94/74	2.3	---	122
	CAPPA	---	---	---	---	---	133	132	26	0.2	---	28
 ▲ LFM 3T 4666	LFM-3T-4666	3	46X66	143	70	18/24	174	113	31/37	11.2	6	167
	LFM-3T-4666-V	3	46X66	143	70	18/24	174	113	31/37	13.6	7.5	201
	TOP**	---	---	---	---	---	174	113	7	---	---	90
	STAND	20/28	46x66	---	---	---	174	97	87/55*	---	---	87/46
	CELLA	20/28	46x66	---	---	---	174	110	94/74	2.3	---	127
	CAPPA	---	---	---	---	---	174	117	26	0.2	---	32

TOP = Isolamento superiore e inferiore moduli forno - Top and base insulation - Isolation supérieure et inférieure des modules de four- Aislamiento superior y inferior de los módulos horno

STAND = Supporto- Stand- Support- Soporte

CELLA = Cella di lievitazione - Proofer- Chambre de fermentation- Cámara de fermentación

CAPPA = Cappa- Hood- Hotte- Campana

* Supporto per forni a 4 o 5 camere

* Stand for ovens with 4 or 5 decks

* Support pour les fours à 4 ou 5 chambres

* Soporte para hornos con 4 o 5 camaras

** 2 pezzi per forno

** 2 pieces for oven

** 2 pieces for oven

** 2 piezas para horno

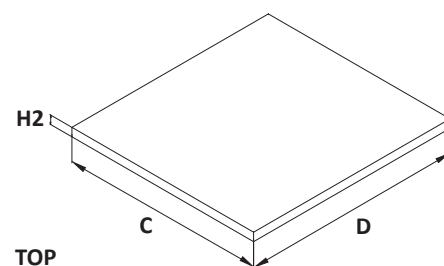
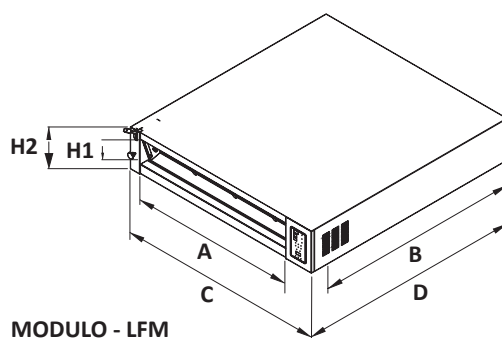
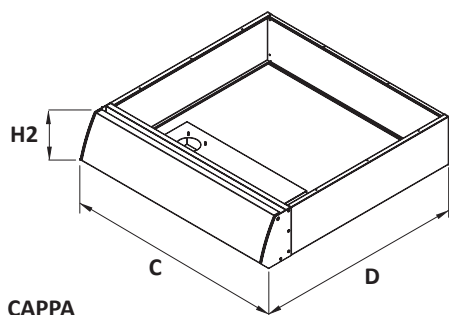

MODUS

	Modello Model Modèle Modelo	Teglie Trays Plaques Bandejas	Dim. teglie Trays dim. Dim. plaques Dim. bandejas	Dimensioni camere Deck dimensions Dimensions Chambres Dimensiones cámaras			Dimensioni esterne Outside dimensions Dimensions extérieures Dimensiones externas			Potenza Power Puissance Potencia	ECO ECO ECO ECO	Peso Weight Poids Peso
				A	B	H1	C	D	H2			
				cm	cm	cm	cm	cm	cm			
LFM 4T 4666	LFM-4T-4666	4	46X66	102	140	18/24	133	183	31/37	16.6	9	209
	LFM-4T-4666-V	4	46X66	102	140	18/24	133	183	31/37	19	10.5	243
	TOP**	---	---	---	---	---	133	183	7	---	---	108
	STAND	20/28	46x66	---	---	---	133	167	87/55*	---	---	116/50
	CELLA	20/28	46x66	---	---	---	133	180	94/74	2.3	---	148
	CAPPA	---	---	---	---	---	133	187	26	0.2	---	31
LFM 6T 4666	LFM-6T-4666	6	46X66	143	140	18/24	174	183	31/37	19.4	10.5	270
	LFM-6T-4666-V	6	46X66	143	140	18/24	174	183	31/37	21.8	12	313
	TOP **	---	---	---	---	---	174	183	7	---	---	137
	STAND	30/42	46x66	---	---	---	174	167	87/55*	---	---	139/60
	CELLA	30/42	46x66	---	---	---	174	180	94/74	2.3	---	163
	CAPPA	---	---	---	---	---	174	187	26	0.2	---	36



TOP = Isolamento superiore e inferiore moduli forno - Top and base insulation - Isolation supérieure et inférieure des modules de four - Aislamiento superior y inferior de los módulos horno

STAND = Supporto- Stand- Support- Soporte

CELLA = Cella di lievitazione - Proofer- Chambre de fermentation- Cámara de fermentación

CAPPA = Cappa- Hood- Hotte- Campana

* Supporto per forni a 4 o 5 camere

* Stand for ovens with 4 or 5 decks

* Support pour les fours à 4 ou 5 chambres

* Soporte para hornos con 4 o 5 cámaras

** 2 pezzi per forno

** 2 pieces for oven

** 2 pieces for oven

** 2 piezas para horno

